

MK series 150HP



MKS series 180HP



OPZIONI TRASMISSIONI - DRIVE OPTIONS

Versione per
azionamento con
motore idraulico
SAE J 744 tipo D

SAE J 744 - D Type
direct coupling

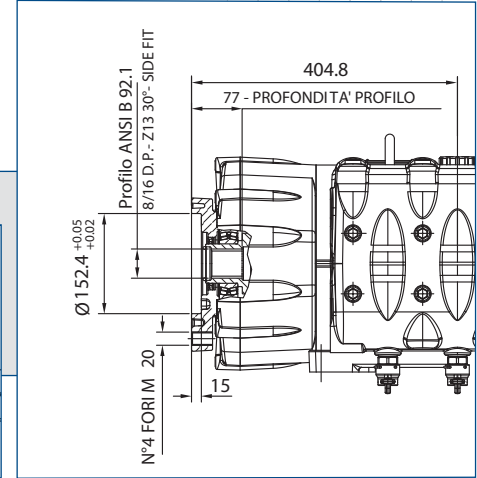
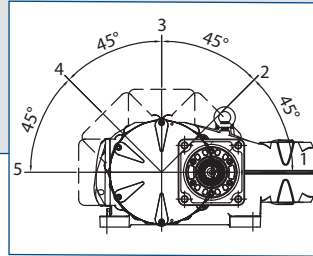
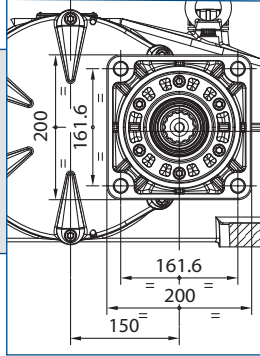

DIMENSIONI D'INGOMBRO - OVERALL DIMENSIONS

MK- MKS Series: MK 40 - MK 45 - MK 50 - MKS 40 - MKS 45 - MKS 50

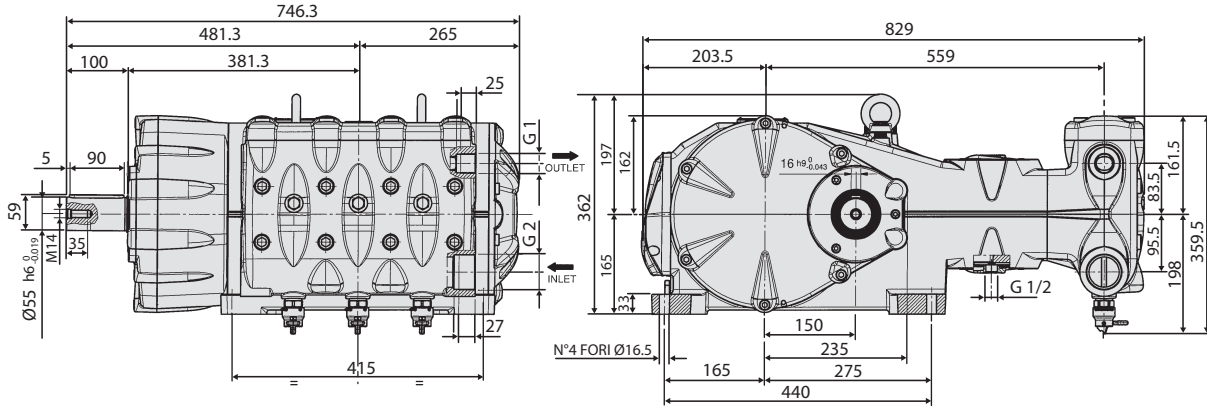

MK-MKS Series: MK 55 - MK 60 - MK 65 - MKS 55 - MKS 60 - MKS 65

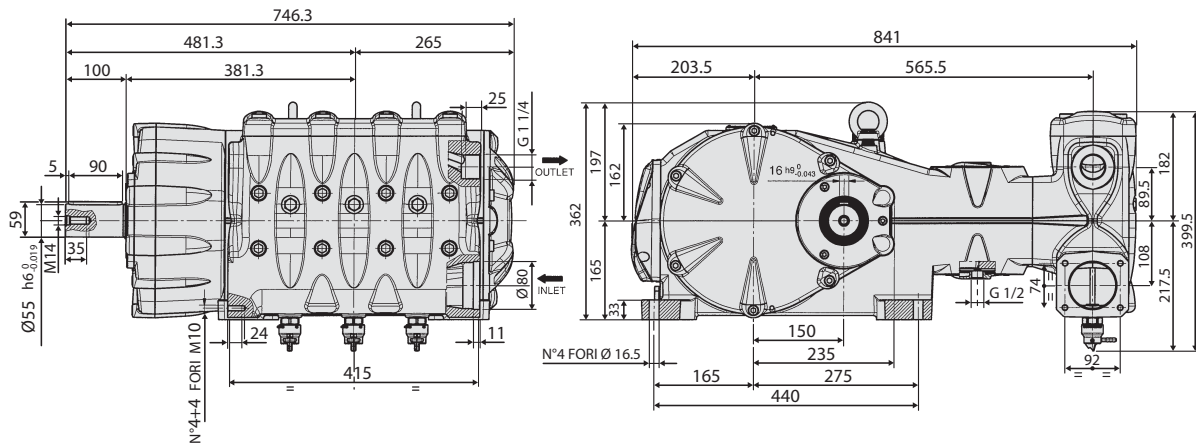

KIT DI CONNESSIONE - CONNECTION KIT - MK 55 - MK 60 - MK 65 - MKS 55 - MKS 60 - MKS 65

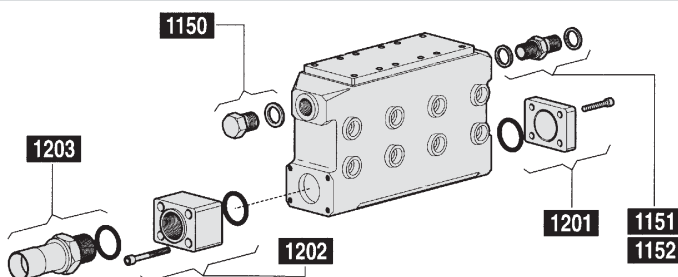

KIT 1150	OUTLET	G 1" 1/4
KIT 1151	OUTLET	G 1" 1/4 - G 1" 1/2
KIT 1152	OUTLET	G 1" 1/4 - G 1" 1/4
KIT 1201	INLET	-
KIT 1202	INLET	G 3"
KIT 1203	INLET	O.D. Ø 90 mm E

Dim.: mm